

Model PH-44 Headset

The PH44 headset is a super lightweight, dual-sided headset for the ultimate in day long comfort. The PH-44 features high quality dynamic earphones with a dynamic noise cancelling microphone on an adjustable boom that can be bent to practically any mouth-to-mic position. The unit has a straight cord and is available in various connector configurations.

Parts List

Item	Description	Qty.	Part No.
1	Windscreen	1	59835-000
2	PT-Pan Head Screw, KA15 x 6 (.236) LG, Black	4	590404-360
3	Glider Spring	2	64305-000
4	Housing Assy	1	64308-106
5	Housing Assy	1	64308-110
6	Glider Assy	2	64310-000
7	Cord Amp Assy	1	64311-054
8	Boom Mic/Housing Assy	1	800499-101
9	Headband Assy	1	64352-033
10	Housing, Rear	1	800504-001
11	Ear Cushion	2	F.01U.253.600
12	Connector, PH-44, XLR-4F	1	35320-004
	Connector, PH-44R, XLR-4M	1	35398-004
	Connector, PH-44R5, XLR-5M	1	35398-005
	Connector, PH-44A5, XLR-5F	1	35320-005
	Connector, PH-44R6, XLR-6M	1	35398-009

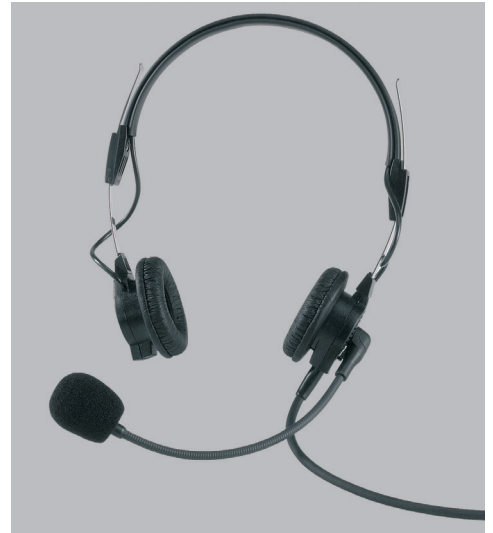

Exploded View

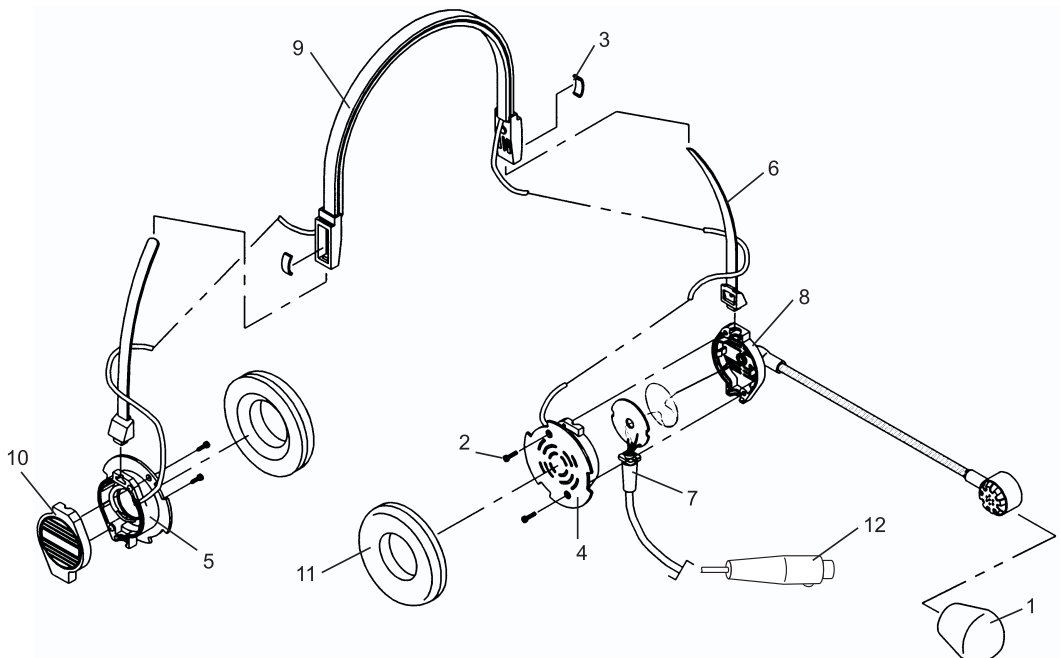

Specifications

Receiver Type.....	Dynamic
Receiver Impedance.....	300Ω
Microphone Type.....	Dynamic
Microphone Impedance.....	200Ω
Weight.....	5.1 oz.
Cord.....	6ft, straight

Wiring Diagram and Connector Wiring

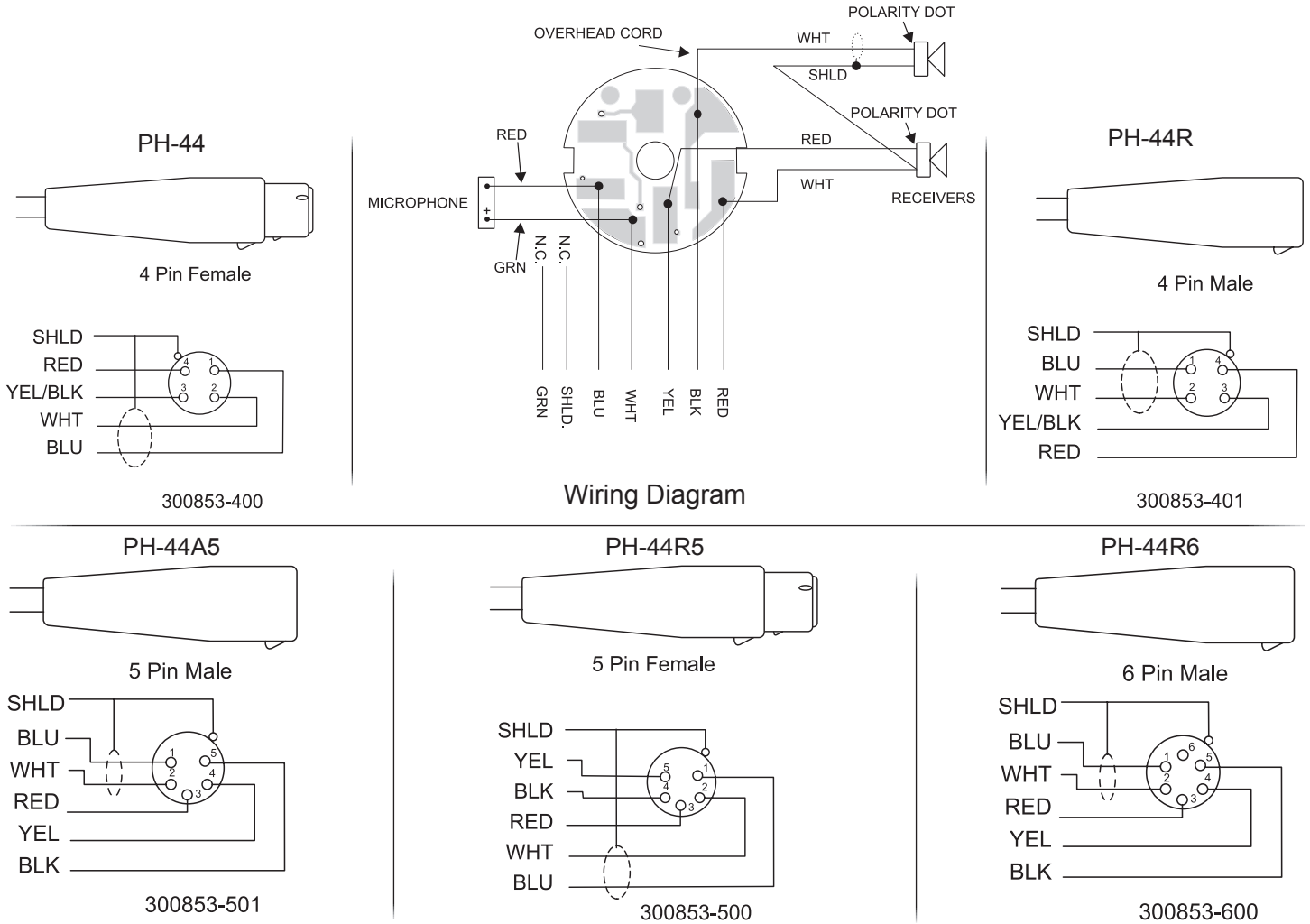

The specification information is preliminary and is subject to change without notification.
 Brand names mentioned are the property of their respective companies.